



OCV™ Reinforcements

Cem-FIL®

GRC Production



Guide to Spray Manufacture

Guide to Spray Manufacture

CONTENTS

<i>Section No.</i>	<i>Page No.</i>
1. INTRODUCTION	1
2. FACTORY LAYOUT	1
3. RAW MATERIALS USAGE	3
4. FORMULATIONS AND MIXING SEQUENCE	5
5. SETTING THE HAND SPRAY ASSEMBLY	7
6. CALIBRATION	10
7. BASIC SPRAY TECHNIQUES	12
8. AUTO/ROBOTIC SPRAY	15
9. SPRAYING OF TYPICAL DETAILS	17
10. COMPACTION	24
11. PROCESS AND QUALITY CONTROL	25
12. CURING OF CRC PRODUCTS	26
13. CLEANING	27
14. CHECKLIST	28

1. INTRODUCTION

This Guide is intended for people involved in the production of Cem-FIL[®] Glass Reinforced Concrete products (GRC).

It gives enough basic information to enable a manufacturer to begin to produce good quality GRC.

It does **not** cover design (see Cem-FIL[®] GRC Technical Data Manual) and assumes that all the necessary equipment has been installed and commissioned according to the manufacturers instructions.

Users of the Guide should refer to the Cem-FIL[®] Technical Data Manual, Cem-FIL[®] Data Sheets and Information Bulletins, all of which contain relevant information not included in this Guide.

This Guide has been prepared on the basis of current good practice. It should not inhibit manufacturers from further developing their own spray production techniques using the basic principles contained in this Guide.

2. FACTORY LAYOUT

By giving serious thought to the planning and layout of the GRC factory many future production problems can be avoided.

The advice given is general because:

- many different types of factories are used to produce G.R.C.
- many different products can be made using the direct spray process.

Factory Areas for GRC Production

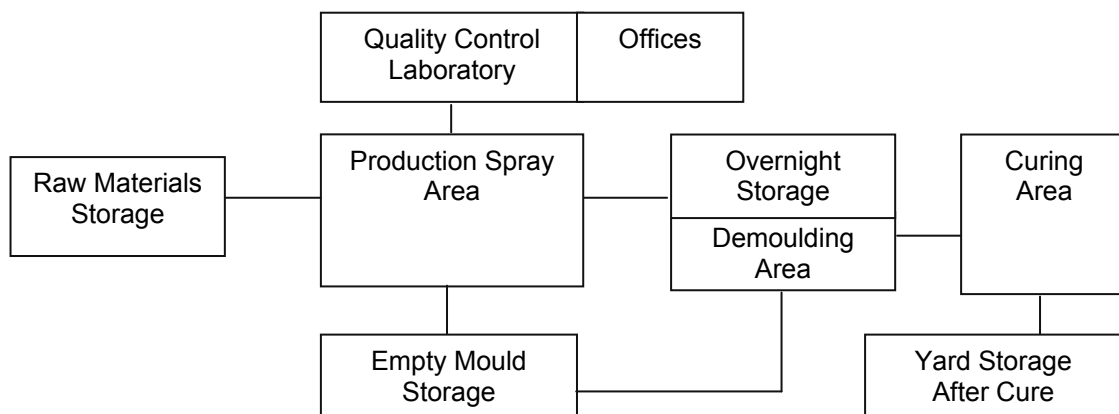

Raw Material Storage

Necessary stock levels depend on system of storage, production requirements, order/delivery time, (i.e. silos, bags). From the stock levels the area required can be calculated. This area should be close to but separate from the spray area and it is important to keep the cement and Cem-FIL[®] glass dry.

Spray Area

This area should include **all** the equipment and services necessary for production and a means of keeping the area clean, (i.e. drainage gullies, settlement pits, cleaning down areas etc). Moulds placed at the correct height for spraying on wheeled trolleys, turntables or conveyors make spraying easier, increase productivity and reduce overspray losses.

A very general guide to the spray area is 80 -100 m² per pump unit.

Mould Storage

The size of this area depends on the ability to stack the moulds. If shapes are awkward or stocks build-up extra space may be required, possibly in an outside area or building. The moulds in this area should be in a condition ready for immediate spraying.

Moulds are expensive and should be protected from damage.

Overnight Storage of Sprayed Moulds

After spraying the units should be removed to an overnight storage space where finishing can be completed. Finishing, (i.e. trowelling, removal of excess material etc) is easier whilst GRC is still fresh and pliable.

The units should then be covered with a polythene sheet and stacked if possible to reduce space. If air-curing polymers are being used, the ambient temperature should be sufficient for the polymer to film-form (usually in the range 10°C -25°C depending on polymer type.)

Demoulding Area

This area is important and should not be treated as a passageway. In addition to demoulding, this space should be used for any units that need remedial work, (i.e. repair of edges, corners, etc). The size of this space depends on unit size, productivity and quality of workmanship.

Curing Area

After demould the Cem-FIL[®] GRC units should be placed in an area where hydration and strength gain can continue. This depends on the curing system employed.

1. Polymeric air-curing additives, (i.e. Forton, Rohm & Haas etc.)

It is recommended that freshly demoulded polymer GRC should be protected from extreme climatic conditions for a further 24 hours. In effect this means keeping the product in the factory for an extra one day after demoulding. During the period up to storage, it is essential that the temperature remains above the minimum film formation recommendations for the particular polymer used, usually 10°C -25°C depending on polymer type.

2. Wet Curing Systems (7 days minimum)

For this system an area is required that will control the temperature and humidity. Good curing conditions are > 20°C and a relative humidity in excess of 95%. The area is best fitted with a water mist spray system in a covered environment.

Consideration should be given to the following:

- a) How the products are to be introduced: either singly or on pallets.
- b) What transportation is to be used: fork lift truck; overhead crane or conveyor system.
- c) How the products are to be positioned: individually; stacked vertically or horizontally.

It must also be remembered that wet curing systems generate excess water which needs to be either recycled or disposed of.

Storage after Cure

A guide to minimum yard area = Curing Area x No. of weeks of stock

Other areas which need to be considered and included in any factory lay-out are:

Quality Control Laboratory
Office Space
Passage Ways

Manpower / Output / Area Guidelines

Production Method	Typical Manpower	Daily Cem-FIL [®] GRC Output		Factory Space (m ²)
		Weight of GRC (tonnes)	Area of GRC @ 10mm thick (m ²)	
(1) Hand Spray	4	0.5 – 1.0	25 - 50	500 - 1000
(2) Hand Spray	8	0.5 – 2.0	75 - 125	500 - 2000
Machine Spray	8 – 12	4 – 6	200 - 300	2000 – 5000
Machine Spray & Mechanical Handling	8 – 12	6 – 10	300 - 500	5000 - 8000

(1) Assumes that the spray team also perform demoulding, mould preparation, handling, etc.

(2) Assumes that a dedicated team perform all demoulding, mould preparation, handling, etc.

3. RAW MATERIALS USAGE

Realistic estimation of material costs avoids unrealistic pricing and should indicate areas where savings can be made without affecting product quality.

The product design determines the thickness of the GRC, but poor thickness control can result in excess material being used. This can be a result of the process, or the complexity of the product. It should be noted that in a good hand-spray operation, a minimum of 15-20% raw material wastage should be allowed for.

Also, unused material has to be taken into consideration, (i.e. wasted mixes, overspray, and material used in calibration and quality control).

One method of calculating the efficiency of the material usage and of how this can be used to estimate realistic costs is described below.

RAW MATERIAL USAGE FACTORS

The principle is first to establish the quantity of raw materials required by the product and then apply a multiplication factor to this quantity to arrive at the expected raw material requirement.

A factor of 1.1 implies that for every 100 kg of GRC needed in a product, 110 kg of raw material will be used. For costing purposes it is necessary to use two factors.

SLURRY FACTOR = $\frac{\text{Average Slurry Used}}{\text{Calculated Slurry}}$

GLASS FACTOR = $\frac{\text{Average Glass Used}}{\text{Calculated Glass}}$

Comparing the actual quantities of glass and slurry used with the design requirements over several weeks of production will produce factors for use in estimating the true raw material costs. If both standard and non-standard products are being made it is useful to have separate factors for both types of production

In all cases the slurry factor should be higher than the glass factor, i.e. there should always be a higher wastage of slurry.

Using Factors to Estimate Raw Material Costs

Calculate the weight of GRC required by the design (Wet Mix Weight).

Wet Mix Weight = GRC Area x Design Thickness x Wet Mix Density.

Weight of Cem-FIL[®] Fibre = (Wet Mix Weight) x (Percentage Glass Fibre Content)

Weight of Slurry = (Wet Mix Weight) - (Weight of Glass)

Using these figures:

ESTIMATED TOTAL RAW MATERIAL REQUIREMENT =

$$(GLASS WEIGHT) \times (GLASS FACTOR) + (SLURRY WEIGHT) \times (SLURRY FACTOR)$$

This estimate should be more realistic than an estimate simply based on the surface area and design thickness alone. It is useful to plot glass and slurry factors on a daily basis. This will show trends and will be useful in demonstrating which types of product are less efficient in terms of their use of raw materials.

Weighing GRC products is also a useful method of control.

The cost of poor thickness control and spray techniques can be high.

2 mm extra thickness on 10 mm is a 20% increase of raw material costs!

Typical Factors

	Glass Factor	Slurry Factor
Semi-automatic High Throughput	1.02	1.06
Custom Moulding Factory	1.1	1.3
Prototype Manufacture	1.3	2.0

These are general figures. More accurate factors should be calculated for each product.

4. FORMULATIONS AND MIXING SEQUENCE

The most desirable mix is a smooth lump-free slurry. This is most easily obtained by using a high shear mixer and for consistency water **meters** and admixture **dispensers** are necessary.

The order in which the ingredients are added is important.

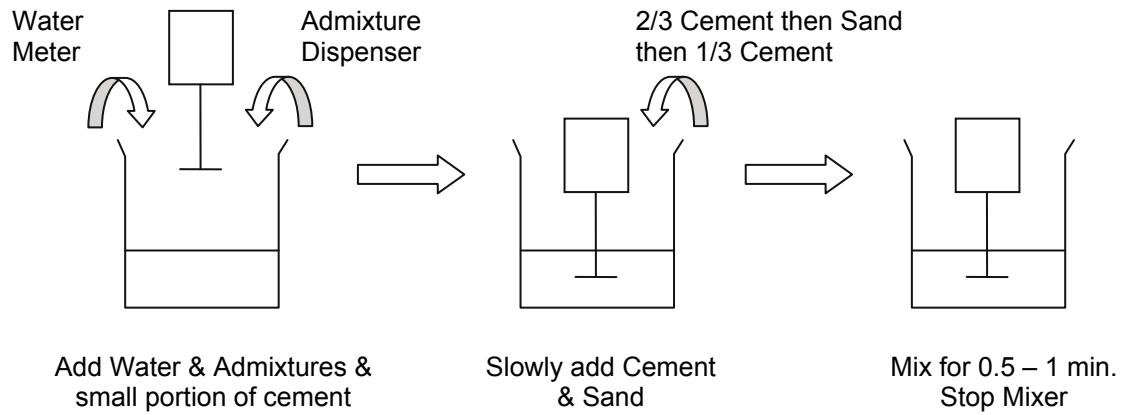

Auto-batch weighing systems and continuous mixers are available for large scale hand spray operations and auto spray systems.

Cement and sand are materials which vary significantly according to their source. Mix proportions may therefore need to be varied from the normal composition in order to achieve a workable mix giving good spray characteristics, with good mechanical properties.

The water / cement ratio should be kept as low as possible, consistent with satisfactory spray characteristics and incorporation of Cem-FIL[®] glass fibre.

Increasing the water / cement ratio leads to a reduction in strength. To aid workability and keep the water / cement ratio as low as possible, super-plasticising admixtures are used at addition rates recommended by manufacturers.

Mixing trials should be performed with locally available ingredients to find the best admixtures with regard to workability times and spray characteristics. This is especially important if a polymeric air-curing admixture is used.

Use the following mixes as a guide for initial mixing trials with locally available raw materials:

		WET CURING	AIR CURING
Cement	kg	50	50
Sand	kg	50	50
Water – litres	Low	16	13.5
	High	17.5	15.5
Superplasticiser	kg	0.5	0.5
Acrylic Polymer	kg	-	5*

* According to Manufacturers Recommendations usually between 3% and 7% polymer solids on cement weight.

In countries with ambient temperatures of $> 30^{\circ}\text{C}$ it is recommended that chilled water or ice is used.

Excess water may assist workability initially but eventually will cause problems associated with bleeding, segregation, low mechanical properties and durability.

Slump Test (BS EN 1170-1:1998) (This test is not always suitable for polymer mixes)

This is a useful check on the sprayability of a mix. It is quick and easy to perform. The equipment can be obtained from suitable GRC equipment manufacturers.

The plastic tube is placed centrally onto the plexiglass target plate and filled with slurry. If necessary, air bubbles are expelled by gently tamping the mix. The slurry top should be levelled with the edge of a spatula.

The tube is lifted vertically off the plate with a slow continuous motion allowing the slurry to flow over the concentric circles on the target plate. The slump is measured by the number of rings covered by the slurry. Given standard formulations 2-3 rings is the normal range to be aimed for, depending on the ambient temperature.

The consistency of the mix can affect the spray characteristics and hence the pressures used in atomisation.

Maintaining a constant slump means that the sprayability of the mix will be constant. This will make spraying easier and should make compaction more efficient.

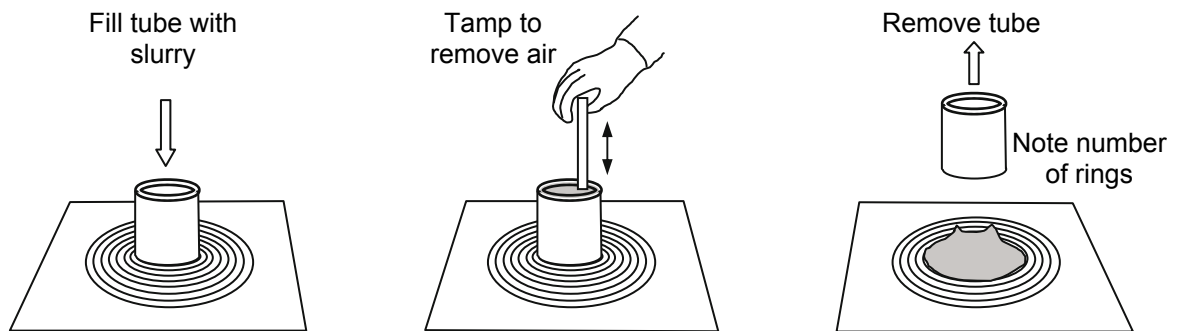

The consistency and quality of the mix can be affected by:

- | | |
|----------------------|---|
| Cement age and type: | Cold cement – low strengths
Warm cement – false sets |
| Sand grading: | Use the correct grade (clean and dry)
Dirty or wet sand can affect workability and strength
A high fines content increases water demand |
| Water temperature: | Too cold – can retard the setting
Too hot – can cause the mix to “flash” set |
| Superplasticisers: | Match the most suitable superplasticisers with the cement so as to obtain the best extended slump values |
| Polymer: | Store in the conditions recommended by the supplier |
| Mixing time: | By attaching an ammeter on the mixer the power required to mix the formulation can be monitored more closely and consistent viscosity mixes can be provided |

Any change in consistency during spraying should immediately be reported to the management and checks made on the slurry output and quality.

N.B. If a 'false set' occurs in the mixer, stop mixing for 30 seconds and then re-mix for 30 seconds.

5. SETTING THE HAND SPRAY ASSEMBLY

There are several types of glass fibre chopping guns which are available for use with Cem-FIL[®] glass fibre. Most processes use the concentric spray unit. The concentric spray unit delivers both slurry and chopped glass from a single outlet and reduces glass fibre losses.

The advantages of the concentric gun over the old twin arrangement are as follows:-

1. Less waste (particularly of Cem-FIL[®] glass fibre)
2. Better thickness control
3. Less tiring to use (lighter in weight)
4. Requires less operator skill

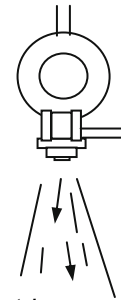

Concentric spray gun

When using a concentric spray gun, the following points are important.

1. The slurry formulation **must** be sieved as it is poured into the pump hopper to remove larger particles which will otherwise block the spray gun.
2. Concentric guns all have a water wash facility and this **must** be used to clean the slurry chamber when any intermittent stoppage of spraying occurs.
3. The spray gun port **must** be thoroughly cleaned at the end of any production session.

The distance from the mould and spraying at 90° to mould face is not as critical with the concentric compared with twin spray guns but it is still important that spraying is smooth and even.

Fibre Chopper Assembly

The design of the fibre chopping assembly is generally common to all types of equipment used in GRC production. The general arrangement of the chopping system is shown below:

Setting

1. Blades

These should be set in the chopping barrel such that they stand proud by 1.0 - 1.1mm.

Normally 3 blades are used, but most chopping barrels have provision for 6 blades if different fibre lengths are required.

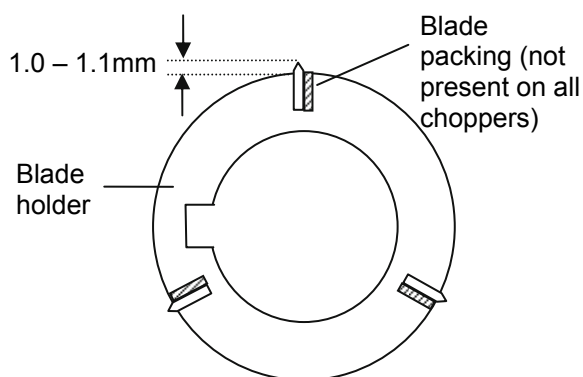

Blade Setting

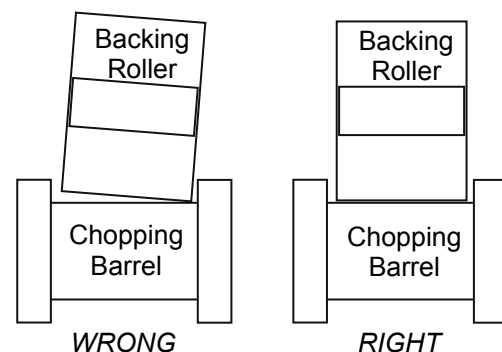

Backing Roller Setting

2. Backing Roller

This should 'kiss' the chopping barrel sufficiently to transmit movement. The backing roller should not interfere with the flanges of the chopping barrel and must be parallel to it.

3. Chopping Barrel

When the chopping barrel is rotated by thumb pressure on the outer flange of the chopping barrel, a small effort should be required to move the blade as it passes the backing roller.

The countersunk Allen screw on the flange of the chopping barrel must be screwed home tightly to avoid the end plate working loose during production and causing blade breakage.

4. Backing Roller Spring

This should be **lightly** touching and parallel to the backing roller.

If settings are:

1. Too loose:
 - Short fibres
 - Roving falls out when spraying stops
2. Too tight:
 - "Ballooning" on entry into spray gun
 - Loops and catenary in roving strand
 - Brake effect on backing roller

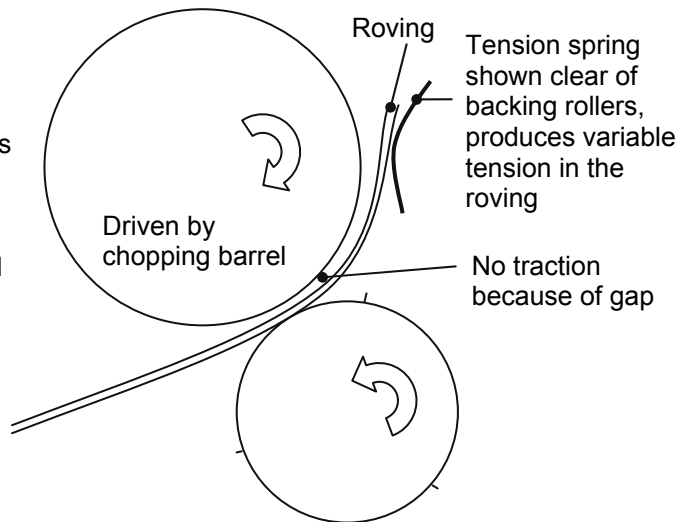

Backing Roller Spring Setting

Maintenance

Blades

It is good practice to change blades before they get too worn, so that production runs can be kept free from interruptions. The chopping guns should be inspected daily, preferably at the end of the day when production has ceased. Blades wear at the centre and experience will quickly show whether any blade changes are necessary.

It is also good practice to have spare chopping guns or chopping barrels available to minimise production down-time.

Wear and Chipping of Blades

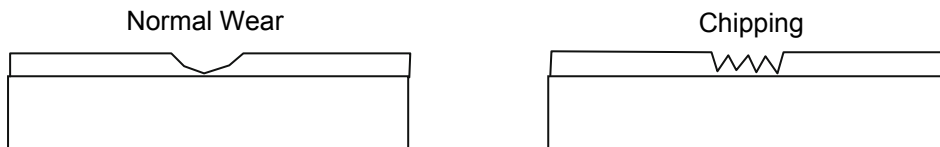

Chipping can be due to any of the following faults:

- Incorrect setting of the blades in their holder (too proud).
- Excessive pressure between blade and backing roller.
- Blades of incorrect hardness.
- Bearings on air motor worn, giving blades a 'hammer' action.
- Backing roller eccentric on its spindle, 'hammer' action results.

Backing Roller

When this is worn, long strands are likely to be produced. The roller should be skimmed flat or replaced.

Air Motor

The air filter cap should be periodically cleaned and the oil level in the compressed air supply checked.

The exhaust ports can sometimes be blocked and should be kept clean.

Backing Roller Spring

This can be accidentally moved when changing blades or backing rollers and should be checked to see that it is lightly touching the roller.

Slurry Atomisation Assembly

The ambient temperature and productivity of the factory regulates the frequency of cleaning. Always use the water wash facility when intermittent stoppages occur and also with longer stoppages, (e.g. meal times/end of spray session). The individual ports should be cleaned, preferably with a metal brush or similar special tool which some manufacturers provide.

Fault Finding

Fault	Cause
Fibre blockage in gun	<ul style="list-style-type: none"> - Air mover incorrectly set - Broken or worn blades - Misalignment of backing roller/chopper barrel - Variable air supply - Dampness or cement inside chopper body
Low glass output/high air consumption from air motor	<ul style="list-style-type: none"> - Worn motor bearings - Air filter blocked - Exhaust ports dirty - Oil bottle empty
Long fibres	<ul style="list-style-type: none"> - Worn or chipped blades - Worn backing roller
Varying length and short fibres	<ul style="list-style-type: none"> - Inadequate tension from spring
'Ballooning' of roving input	<ul style="list-style-type: none"> - Excessive tension on spring - Worn or distorted backing roller - Worn spring
Variation of glass output	<ul style="list-style-type: none"> - Variable air supply - Misalignment of feeder tube affecting spring tension

General guide to spray pressures for concentric guns

	Air Mover		Atomiser	
	lb/in ²	kg/cm ²	lb/in ²	kg/cm ²
K & C Mouldings (Downland)	35 - 45	2.5 - 3.1	50 - 60	3.5 - 4.2
Spray-Tech	20 - 30	1.4 - 2.1	30 - 40	2.1 - 2.6

Ensure that the feed line is adequate for the volume required.

Ensure that slurry quality is good and that it is lump free, i.e. sieve the mix (use a vibrator mounted on the sieve for speed).

Air Supply: The air supply required by a spray pump and concentric gun is typically: 60 cubic feet per minute at 100 psi, or 30 litres per second at 7 bar.

6. CALIBRATION

The strength of GRC composites depends upon the Cem-FIL[®] glass fibre content, which for all hand spray operations should be at least 5% by weight.

Before starting to spray, it is necessary to calibrate the slurry spray and glass depositor outputs using the Bag and Bucket Tests.

For a typical 12 kg/min slurry output, the glass depositor output should be roughly 630g/min.

(In some specifications 5% is the MINIMUM glass content allowed. In this case it is suggested to use a target glass content of 5.3%).

1. Bag Test (CEM/QC/003) EN 1170-3

This is used to set the delivery of the correct amount of chopped fibre from the glass depositor. This should be carried out under actual running conditions.

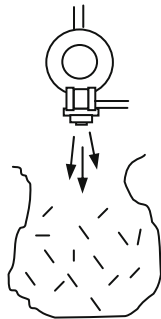

1. Weigh empty bag (W grams)
2. Chop glass into bag for 15 seconds
3. Weigh bag and fibre (G grams)
4. Subtract weight of bag
5. Glass output = $(G - W) \times 4 \text{ g/min}$
6. Adjust air pressure to glass depositor until required output is achieved - note pressure setting.

Once calibration is achieved carry out three measurements. If the variation is more than $\pm 5\%$ then check for variation in the air pressure line.

2. Bucket Test (CEM/QC/002)

This is used to measure the output from the slurry spray. It should be performed under actual running conditions.

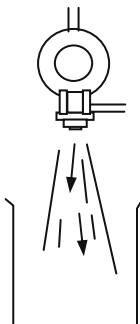

1. Weigh empty bucket (W kg)
2. Spray slurry into bucket for 30 seconds
3. Weigh bucket and slurry (S kg)
4. Subtract weight of bucket
5. Slurry output = $(S - W) \times 2 \text{ kg/min}$
6. Adjust pump output until required output is achieved – note pump setting

(An alternative method for measuring the fibre content of fresh GRC and calibrating the equipment is contained in BS EN 1170 – 3 Measuring the fibre content of sprayed GRC.)

BAG AND BUCKET CALIBRATION TABLE (for 5% glass content)

GLASS OUTPUT	g/15 SECS	KG/MIN	SLURRY OUTPUT	KG/MIN	KG/30 SECS
	130	0.52		9.88	4.94
	132.5	0.53		10.07	5.035
	135	0.54		10.26	5.13
	137.5	0.55		10.45	5.225
	140	0.56		10.64	5.32
	142.5	0.57		10.83	5.415
	145	0.58		11.02	5.51
	147.5	0.59		11.21	5.605
	150	0.60		11.4	5.7
	152.5	0.61		11.59	5.795
	155	0.62		11.78	5.89
NORMAL OUTPUT FOR CONCENTRIC GUN					
	158	0.632		12	6
	160	0.64		12.16	6.08
	162.5	0.65		12.35	6.175
	165	0.66		12.54	6.27
	167.5	0.67		12.73	6.365
	170	0.68		12.92	6.46
	172.5	0.69		13.11	6.555
	175	0.70		13.3	6.65
	177.5	0.71		13.49	6.745
	180	0.72		13.68	6.84
	182.5	0.73		13.87	6.935
	185	0.74		14.06	7.03
	187.5	0.75		14.25	7.125
	190	0.76		14.44	7.22
	192.5	0.77		14.63	7.315
	195	0.78		14.82	7.41
	197.5	0.79		15.01	7.505
	200	0.80		15.2	7.6
	202.5	0.81		15.39	7.695
	205	0.82		15.58	7.79
	207.5	0.83		15.77	7.885
	210	0.84		15.96	7.98
	212.5	0.85		16.15	8.075

Calculation Examples

a) **Glass Output** = $\frac{\text{Slurry Output (kg/min)} \times \text{Glass Content (\%)}}{100 - \text{Glass content \%}}$ kg/min

If the Glass Content should be 5% and the Slurry Output is 12.6 kg/min the required Glass Output should be:

Glass Output = $\frac{12.6 \times 5}{95}$ = 0.663 kg/min = 166 g per 15 sec.

b) **Slurry Output** = $\frac{\text{Glass Output (kg/min)} \times (100 - \text{Glass Content (\%)})}{\text{Glass Content \%}}$ kg/min

If the Glass Output is 0.7 kg/min and the Glass Content should be 5% the required Slurry should be:

Slurry Output = $\frac{0.7 \times 95}{5}$ = 13.3 kg/min

1. The chopped fibres from the Bag Check are scrap and are not suitable for premix unless they are chopped from Cem-FIL[®] 61/2 roving (a dual purpose roving).
2. The slurry can be returned to the pump hopper.
3. The Bag and Bucket Check should be carried out whenever there is a change in the mix, whether deliberate or accidental.

PROCEDURE

1. Set the glass depositor air pressure gauge to the required level.
2. Carry out the Bag Test for the Cem-FIL[®] glass fibre.
3. Read the required Slurry Output from the Table on the previous page.
4. Set Slurry Output using Bucket Test.

NOTE

If the glass depositor output falls when using the same air pressure then the air motor or the filter to the air motor requires maintenance, or the oil bottle feeding the air motor has run dry.

7. BASIC SPRAY TECHNIQUES

Before Spraying

- Check
- that the mould is clean and has been treated with appropriate mould release agent.
 - that the correct rollers and trowels are clean, and water is available for keeping them clean.
 - that the correct sieved mix is in the hopper.
 - that spray pressures are correct.
 - that the bag and bucket checks have been carried out.
 - that the mist coat (generally not more than 1 mm thick) has been applied correctly, i.e. well atomised by using either a separate mist coat gun or by increasing the atomising pressure on spray gun. **Avoid over-thick, unreinforced mist coats, which will crack later.**

NOTE

If an architectural face coat (generally thicker than a mist coat) is being used this can be compacted by gently using a paint-brush. Such face coats would normally contain an acrylic polymer, which helps to prevent cracking, and may also be reinforced by dispersible fibres (e.g. Cem-FIL[®] 70/30) which should be invisible in the finished surface.

During Spraying

Good quality Cem-FIL® GRC is produced when there is a minimum of trapped air (achieved with low pressures and good compaction) and when the fibres are well distributed (correct percentage and good spray technique).

1. It is normal good practice to spray in layers (roughly 3-4 mm thick) at a speed likened to “waltz-time”.
2. Each layer should be compacted before the next layer is sprayed.
3. Each layer consists of spraying in alternate directions.

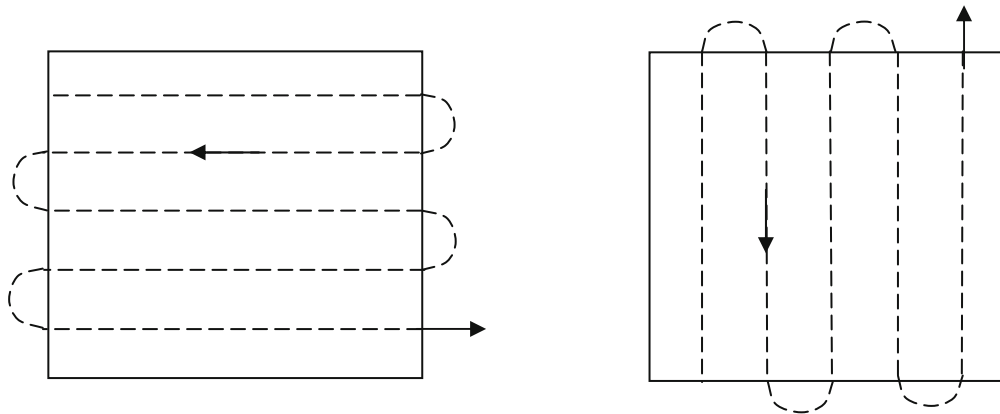

The cone shaped spray forms a strip of GRC on the mould. The next cone strip in reverse direction should overlap the preceding spray strip by up to 50%. Spraying should continue in this fashion. A well sprayed unit should not show any discrete lines of cement or glass.

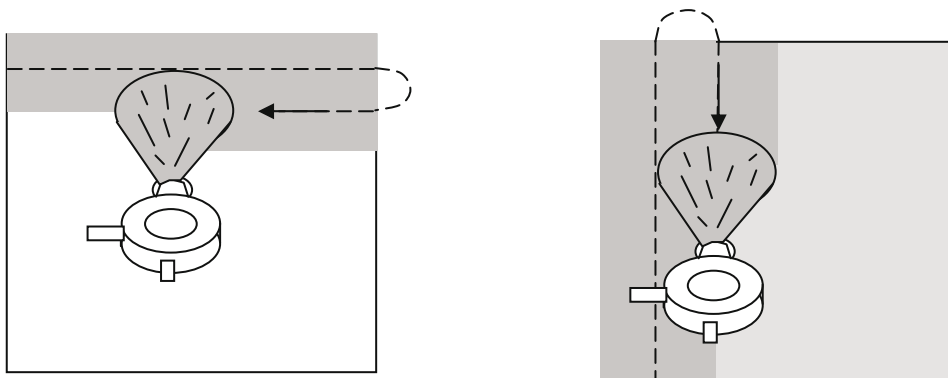

Schematic illustration showing 50% overlap of layers

4. It is important that any one layer of GRC is not allowed to set before the application of the next. If this happens a plane of weakness will be formed in the GRC, which will cause delamination,
5. Various systems of thickness control can be used:
 - a. Pin gauges
 - b. Guide plates for datum points

After Spraying

- 1) Any work that needs to be done to the unit is best done whilst the GRC is still 'green', i.e. cleaning off over-sprayed material, fitting inserts and fixings, trimming etc.
- 2) Trowel level and smooth.
- 3) After trowelling is finished the mould must be covered with a polythene sheet even if polymers are being used. The temperature should be maintained at approx. 20°C to assist in developing the initial early strength. Demoulding can normally be performed after 16-24 hours.
- 4) After demoulding any surface blemishes, damage to edges, and corners and any 'flashing' can be corrected/removed before placing in a curing chamber.

Whether wet curing or polymer curing is being used the GRC should not be allowed to dry out during its time in the mould, and should be protected by covering with polythene sheeting.

SEQUENCE OF SPRAYING MOULDS

The sequence of spraying moulds is important and should be decided before spraying begins.

FEMALE MOULD

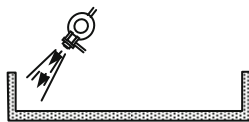

Spray Edge Detail and Edge of Base First

MALE MOULD

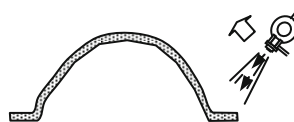

Spray Bottom of Mould First

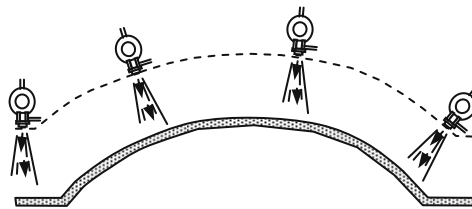

Always Spray Perpendicular to the Mould Surface and Maintain Constant Height

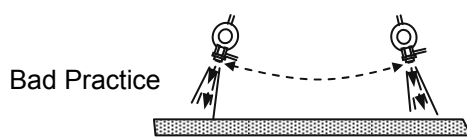

Bad Practice

Swinging spray assembly in an arc produces poor quality material and excessive over-spray

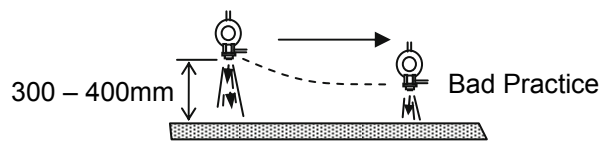

300 – 400mm

Bad Practice

Failure to maintain constant height produces poor compaction and poor integration of layers

Some manufacturers prefer to introduce two rovings into the gun, and increase the slurry output to achieve a higher output. In this case the gun may be held further from the mould and the spray pattern adjusted changing the atomising pressure.

There will always be some fibres falling out of the spray cone. These fibres will tend to collect in corners. These loose fibres must be removed before these areas are sprayed. The loose fibres must not be over-sprayed otherwise dry fibre will be present on the surface after demoulding.

8. AUTO/ROBOTIC SPRAYING

Crosshead Machine Spray (Auto Spraying)

Machine spray of GRC, based on a crosshead traverse system is used in the manufacture of flat or low profiled single skin or sandwich panels, and sheets that can be folded to shape whilst the GRC is still fresh using hinged moulds.

Advantages

- Reduced manpower
- Sprays accurate thickness in one pass
- Good thickness control, reduced wastage
- Trowelling / compaction can be mechanised
- Line production can be achieved
- Freshly sprayed material can be bent or folded

Disadvantages

- Initial capital cost
- Steps and recesses cannot be produced by this method and must be pre-sprayed by hand
- Deep edge details require hinged moulds or pre-spraying
- The traverse width must be easily adjustable for varying mould widths

Production

Achieving a good fibre distribution is necessary to produce good mechanical properties. The object is to produce GRC which gives strength properties that are similar in any direction whether the samples are tested with the top or bottom faces in tension and also in both longitudinal and transverse directions.

Although material thicknesses up to 12 mm can be achieved in one pass under the spray head the number of oscillations (i.e. the speed of the cross-head itself) should be kept to a maximum so that the composite is made up of a number of thin layers of GRC. In general, the higher the slurry output and the thinner the product the higher the required crosshead speed.

The thickness of the GRC is dependant on the slurry output, product width and conveyor speed. It is normal to keep the slurry output fixed and vary the conveyor speed to suit the product being made.

Cross Head Speed

The cross-head speed is normally in the region of 0.75 - 1 m/sec.

If the cross-head speed is too low in relation to either the conveyor speed, the slurry output or the product thickness then the thickness of the GRC will not be uniform. (See diagram).

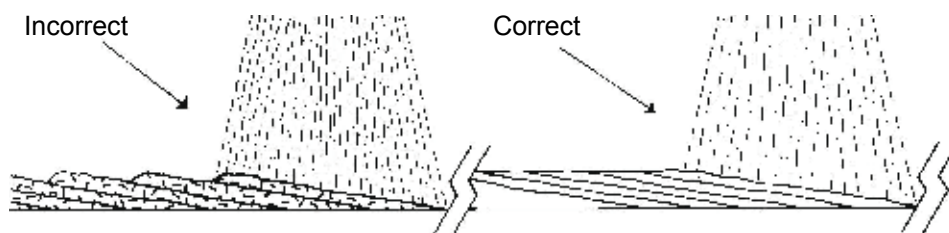

Higher cross-head speeds may be desirable when producing thin and narrow products at a high slurry output. However the inertia of the cross-head itself means that this is not always possible. Therefore, in these cases it is usually necessary to reduce slurry output and conveyor speed to achieve the same result.

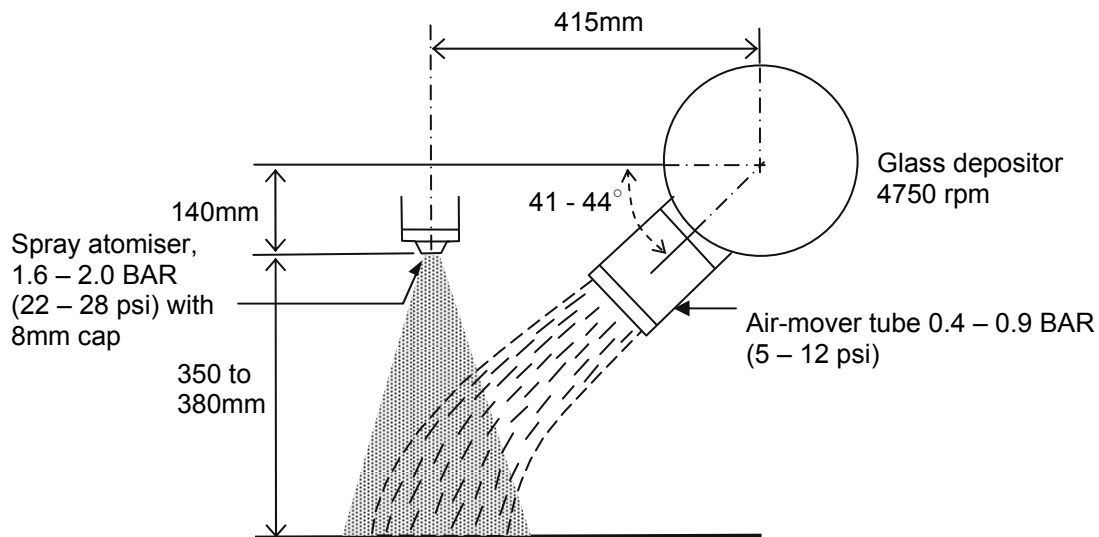

Arrangement of spray assembly with a single chopper

This is the basic geometry for a single set unit suitable for slurry outputs of up to 18 kg/min.

Setting Notes

The angle of the depositor can be moved to direct the fibre to give the best distribution. The angle reduces as the slurry output increases. Also the air mover can be adjusted up or down from a 'norm' setting of 8 lb/in² (0.6 bar).

The atomising pressure controls the diameter of the spray pattern. As the pressure increases the diameter of the spray increases and the fibre will be deflected to one side creating a heavy slurry coating on the top surface.

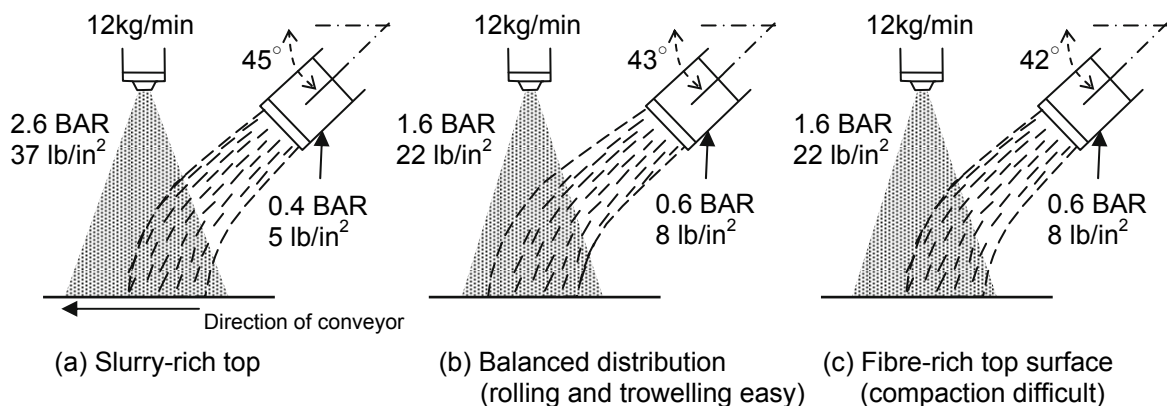

Illustration of Effect of Atomising Pressure and Angle of Deposition.

Using the system illustrated it has become clear that there is a practical limitation to good lay-down when the spray increases above 18 kg/min. The increased volume and increased atomisation pressure reduces the penetration of the fibre and therefore creates an imbalance and the mould surface becomes fibre-rich.

For deposition rates higher than 18 kg/min. systems are available such as twin glass depositor machines and high-output concentric sprayers. If this is the requirement, then contact with the machinery manufacturers or OCV Reinforcements is advisable.

Robotic Spraying

Computer controlled machines have been developed for profile spraying which also spray at outputs up to 35 kg/min. These are based on the concentric principle of spraying. Profiles can be memorised for exact repeatability and the computer also controls conveyor speed, slurry pump speed and water flush controls. For further information please refer to your representative at OCV™ Reinforcements.

9. SPRAYING OF TYPICAL DETAILS (Sketches are not to scale)

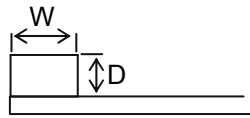
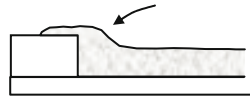
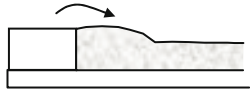
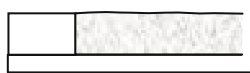
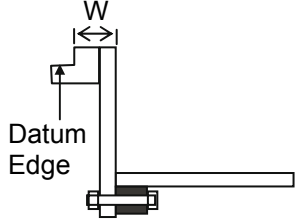
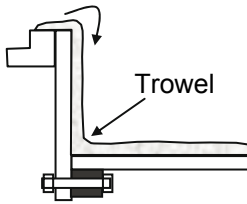
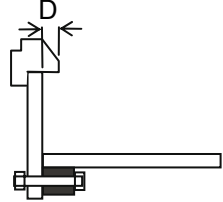
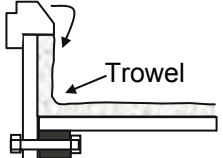
DETAILS	METHOD	DIAGRAM
1. EDGES TO FLAT AREAS	a) Attach overspray strip to edge of mould with: D = GRC design thickness W = at least 50mm	
	b) Spray in layers leaving overspray as shown. Do not spray final layer. Tuck material into corner with special-purpose trowel or roller.	
	c) Fold back overspray onto panel surface with trowel.	
	d) Spray final layer to design thickness. Roll and trowel to give flat, neat edge.	
2. EDGES TO RETURNS AND OTHER VERTICAL SURFACES USING A MOULD WITH REMOVABLE SIDE AND A DATUM EDGE METHOD A	Mould type should be as shown. The side of the mould is held in place by bolts or by quick release clamps. This makes demoulding easier. Spray as in 1.	
	Fold back overspray. Spray final layer to design thickness and trowel edge to correct thickness.	
METHOD B	Mould type should be as shown. D = GRC design thickness Spray as in 1.	
	Fold back overspray. Tuck material into corner. Spray to design thickness D.	

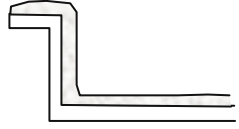
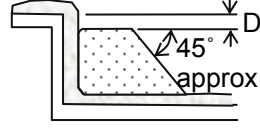
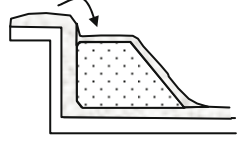
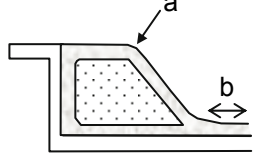
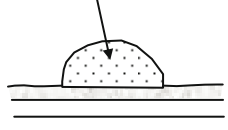
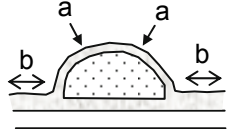
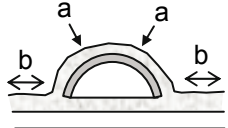

SPRAYING OF TYPICAL DETAILS (Continued)

DETAILS	METHOD	DIAGRAM
3. EDGE RIBS USING FOAM FORMER	a) Spray in layers. Compact with rollers and check correct thickness on side-wall and base.	
	b) Place pre-cut foam former with edges chamfered as shown. $D = \text{design thickness} + 10\%$	
	c) Spray over former and also between former and overspray. Fold back overspray with a trowel.	
	d) Spray to correct thickness. Pay special attention to thickness at (a) and ensure sufficient overlap of new and original sprayed GRC at (b).	
4. CENTRE RIBS USING FOAM FORMER	a) Spray and compact front face in layers. Check thickness then place former, ensuring that the top is at the correct height.	Foam rough-cut or pre-cut to a semi-circular or other profile 
	b) Spray over back and sides of former in layers. Check thickness is correct, especially at (a). Taper the thickness at (b) ensuring a gradual change.	
5. CENTRE RIB USING PRESsprayed GRC VOID FORMER	As above, but using a 3 – 5mm thick GRC void-former. The thickness of the void former is not counted as part of the rib design thickness.	

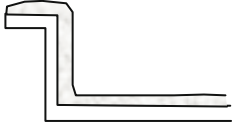
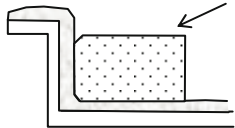
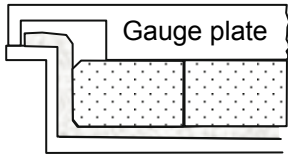
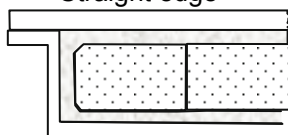
SPRAYING OF TYPICAL DETAILS (Continued)

DETAILS	METHOD	DIAGRAM
<p>6. SANDWICH PANELS USING ORGANIC FOAM CORE</p>	<p>a) Spray and compact mould face and sides in multiple layers, as in stage (a) of example (3). Check thickness.</p>	
	<p>b) Precut foam blocks (500 mm sq. approx) to fill mould with loose fit between blocks. Coat sides and base of blocks with mortar and bonding agent (e.g. Acronal). Place in mould, chamfered side blocks first, ensuring block is bedded into base and does not drag material off side walls.</p>	
	<p>c) Check that the top surface of the foam blocks is at the correct height using a gauge plate as shown. Spray the first 3 mm layer on top of the blocks, then fold over-spray onto this layer and compact.</p>	
	<p>d) Continue spraying onto the foam blocks and compacting. Check thickness. Once required thickness is achieved finish the back face of the panel with a trowel and using a straight edge to check the level.</p>	

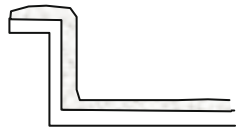
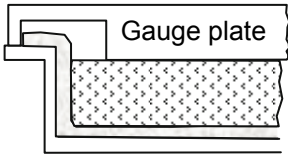
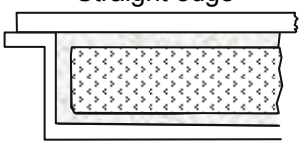
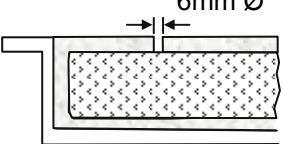

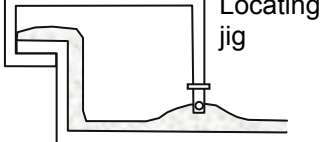
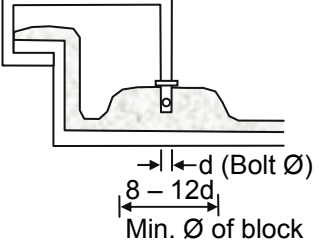

SPRAYING OF TYPICAL DETAILS (Continued)

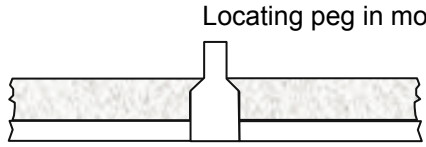
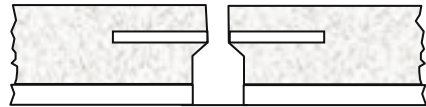
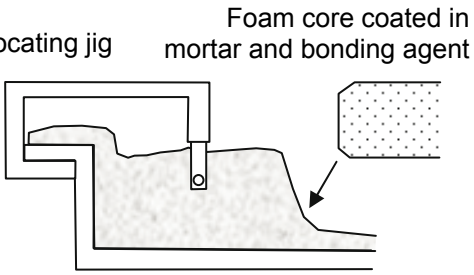
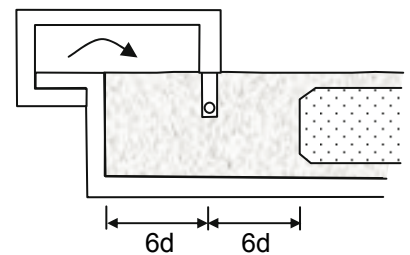
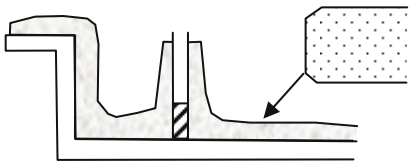
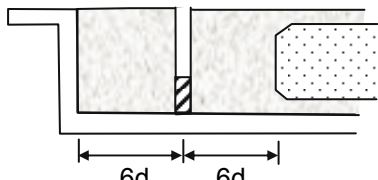
DETAILS	METHOD	DIAGRAM
7. SANDWICH PANELS USING POLYSTYRENE BEAD AGGREGATE CEMENT (PBAC) CORE	a) Complete stage (a) of example (3).	
	b) Fill mould with PBAC mix. Tamp to remove air pockets. Use gauge plate to check depth. Spray first layer over PBAC. Fold back over-spray and roll to compact.	
	c) Continue spraying and compacting. Check thickness. Once required thickness is achieved finish the back face of the panel with a trowel and using a straight edge	
	d) Air trapped during the mixing of PBAC concrete can expand during curing. It is necessary to leave a number of 6mm breather holes in the top surface of the panel to allow the release of air. These can be filled with grout after approx. 24 hours.	
8. CAST-IN SOCKET SUSPENDED FIXING FIXINGS FOR SINGLE SKIN PANELS	a) Spray base of panel. Build up thickness of material under fixing point before fixing is put in position.	
	b) Suspend fixing from locating jig and press into sprayed material.	
	c) Complete spraying to correct depth, compact material around fixing. Note: the fixing should be contained in a block of well-compacted material.	

SPRAYING OF TYPICAL DETAILS (Continued)

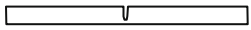
DETAILS	METHOD	DIAGRAM
9. CAST-IN WASHER	a) Spray and compact first layer up to shoulder of locating peg	
	b) Place perforated steel washer on peg and spray and compact to design thickness. Note: Top of Peg can be used as thickness gauge.	
FIXING FOR SANDWICH PANELS 10. CAST-IN SOCKET	Proceed as for stage (a) of example (3). a) Build up thickness under fixing point. Locate fixing. Spray over fixing and onto base. Place core material coated with mortar and bonding agent.	
	b) Spray carefully around socket (with frequent compaction) filling hole. Turn back over-spray and finish spraying top layer over foam core. (d = bolt diameter)	
11. CAST-IN SLEEVE	a) Proceed as 10a but with a sleeve in place	
	b) Spray carefully around the sleeve (with frequent compaction) filling the void. Turn back over-spray and finish spraying the top layer. (d = sleeve diameter)	

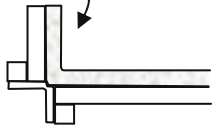
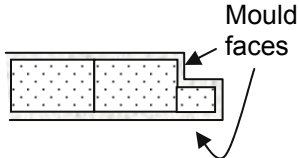
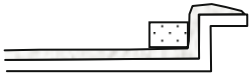
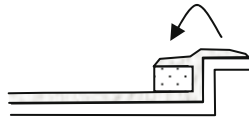
SPRAYING OF TYPICAL DETAILS (Continued)

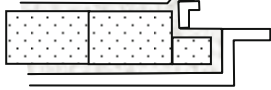
DETAILS	METHOD	DIAGRAM
<p>12. FOLDING MOULD</p>	<p>Typical use is to form edge details on panels.</p>	<p>Polypropylene hinge</p> 
	<p>a) With the side of the mould hinged down layers are sprayed and compacted in the normal manner.</p>	
	<p>b) When the side of the mould is folded up the GRC is rolled or tamped into the corner, and over-spray is folded in.</p>	<p>Fold back overspray</p> 
<p>USE OF RISING SHUTTERS</p> <p>13. JOINTING DETAIL</p>	<p>A typical example of a product requiring a rising shutter is shown.</p>	 <p>Mould faces</p>
	<p>a) Spray the base layer onto the mould in the normal manner, placing the rib core material if required.</p>	
	<p>b) Spray over core and fold back over-spray. Compact and trowel as normal.</p>	
	<p>c) Attach rising shutter and spray onto it in the standard manner.</p>	
	<p>d) Place the main core material and complete the panel as in detail 6.</p>	

SPRAYING OF TYPICAL DETAILS (Continued)

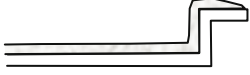
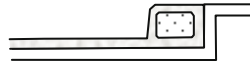
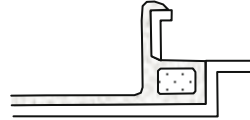
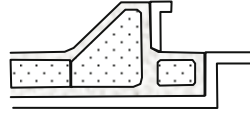
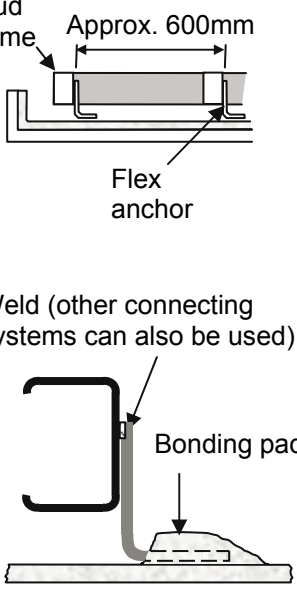
DETAILS	METHOD	DIAGRAM
<p>USE OF RISING SHUTTERS</p> <p>14. NIB DETAIL</p>	<p>a) Spray the base layer into the mould as normal.</p>	
	<p>b) Place foam core in the toe of the panel. Spray over and compact in normal manner.</p>	
	<p>c) Locate rising shutter and spray up the vertical face.</p>	
	<p>d) Fold back over-spray, place rib core and spray over to required thickness. Compact with rollers and trowel to finish as normal.</p>	
<p>15. METAL STUD FRAMES ATTACHED TO SINGLE SKIN PANELS</p>	<p>a) Spray and compact the base layer into the mould as normal.</p> <p>b) Place and support the stud frame so that the flex anchors are just above the GRC surface, but not compressing the surface of the GRC as this can cause discoloration on the finished panel surface.</p> <p>c) Place a pre-made bonding pad or “mushy” of fresh GRC over the foot of the flex anchor and compact gently (making sure that the heel of the anchor is clear of GRC).</p> <p>(For further information please contact OCV Reinforcements)</p>	<p>Stud frame</p> <p>Approx. 600mm</p> <p>Flex anchor</p> <p>Weld (other connecting systems can also be used)</p> <p>Bonding pad</p> <p>Effective area of bonding pad $\geq 155\text{cm}^2$ Bonding pad thickness over anchor foot $\geq 12\text{mm}$</p> 

10. COMPACTION

Brushes, Compaction Rollers and Trowels

1. When spraying a product with an architectural face coat, a brush can be used to gently assist in the release of air from the face coat before the backing GRC is sprayed.
2. Compaction rollers are usually the spring-type and should be kept clean during use by frequent rinsing in a bucket of water.
3. A stiff brush is useful for dabbing the GRC into internal angles and awkward mouldings.
4. Vibrating trowels can be effective and eliminate the need for compacting at 3 mm intervals, but are only really suitable for large flat areas of sprayed GRC.
5. Rollers and trowels are cheap. It can be efficient and economical to make additional special tools for specific purposes.
6. It is good practice to keep rollers and trowels in a water bucket during production. This stops slurry from drying on their surfaces which would reduce their effectiveness.

Time spent in rolling and trowelling
REDUCES
Time spent in making good
AND
Produces a stronger product

Compaction is required to:

1. Form the GRC to the mould shape and finish.
2. Remove entrapped air, thereby increasing GRC density, and strength.
3. Coat each bundle of Cem-FIL[®] glass fibre in the matrix thereby giving stronger bonding.

Brush, Roller and Trowel Techniques

1. Face Mix:
When using a brush to release air from an architectural face coat the action should be gentle so as not to disturb the surface finish. If the mould becomes exposed a second thin spray of face coat may be required before spraying the GRC backing.

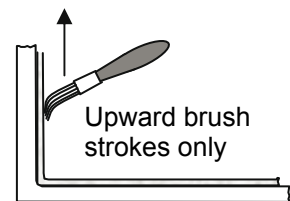

On vertical sections the brushing action should be upward only.

2. Internal Corners:
When using a standard roller care must be taken not to disturb the side wall material (indicated by the arrow in the sketch). If the material is disturbed, moving it back into place with a trowel is not good practice and does not produce good GRC.

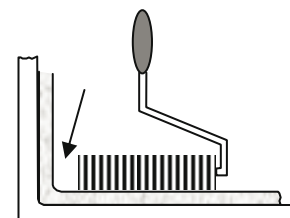

If the material has to be compacted into a corner, it is good practice to use an angled tool or a brush to press the material into the corner.

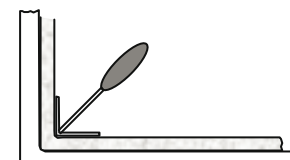

10. COMPACTION

Brushes, Compaction Rollers and Trowels

1. When spraying a product with an architectural face coat, a brush can be used to gently assist in the release of air from the face coat before the backing GRC is sprayed.
2. Compaction rollers are usually the spring-type and should be kept clean during use by frequent rinsing in a bucket of water.
3. A stiff brush is useful for dabbing the GRC into internal angles and awkward mouldings.
4. Vibrating trowels can be effective and eliminate the need for compacting at 3 mm intervals, but are only really suitable for large flat areas of sprayed GRC.
5. Rollers and trowels are cheap. It can be efficient and economical to make additional special tools for specific purposes.
6. It is good practice to keep rollers and trowels in a water bucket during production. This stops slurry from drying on their surfaces which would reduce their effectiveness.

Time spent in rolling and trowelling
REDUCES
Time spent in making good
AND
Produces a stronger product

Compaction is required to:

1. Form the GRC to the mould shape and finish.
2. Remove entrapped air, thereby increasing GRC density, and strength.
3. Coat each bundle of Cem-FIL[®] glass fibre in the matrix thereby giving stronger bonding.

Brush, Roller and Trowel Techniques

1. Face Mix:
When using a brush to release air from an architectural face coat the action should be gentle so as not to disturb the surface finish. If the mould becomes exposed a second thin spray of face coat may be required before spraying the GRC backing.

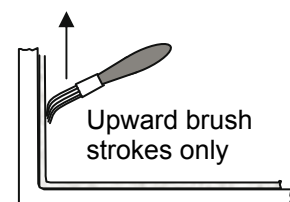

On vertical sections the brushing action should be upward only.

2. Internal Corners:
When using a standard roller care must be taken not to disturb the side wall material (indicated by the arrow in the sketch). If the material is disturbed, moving it back into place with a trowel is not good practice and does not produce good GRC.

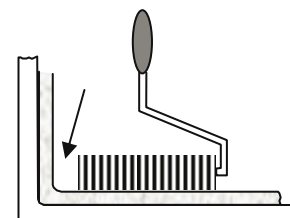

If the material has to be compacted into a corner, it is good practice to use an angled tool or a brush to press the material into the corner.

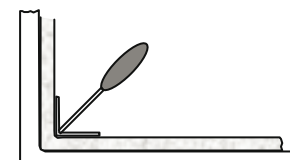

3. External Corners:
 If support is not given to the GRC, material will be squeezed away from the mould leaving a pocket of air down the edge. Thinning of the GRC may also occur. This can be avoided by supporting the side of the sprayed material with a trowel

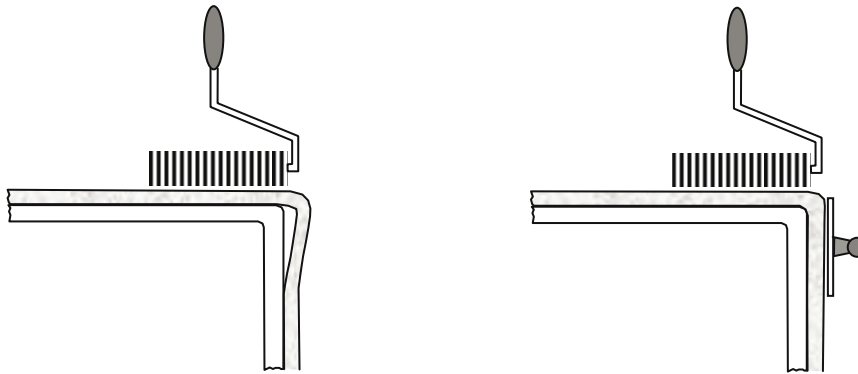

11. PROCESS AND QUALITY CONTROL

Quality control procedures have been established for the Cem-FIL® GRC manufacturing process, to ensure that correct material properties are being achieved and to assess the final product. These procedures are described in the following CEN European Standards:

Process Control

BS EN 1170-1 Measuring the consistency of the matrix - "Slump Test" Method

BS EN 1170-2 Measuring the fibre content in fresh GRC - "Wash out test" (See diagram below)

BS EN 1170-3 Measuring the fibre content of sprayed GRC (Calibration test)

Production of GRC is also controlled by keeping a check on such items as raw material usage thickness of product and final product weight.

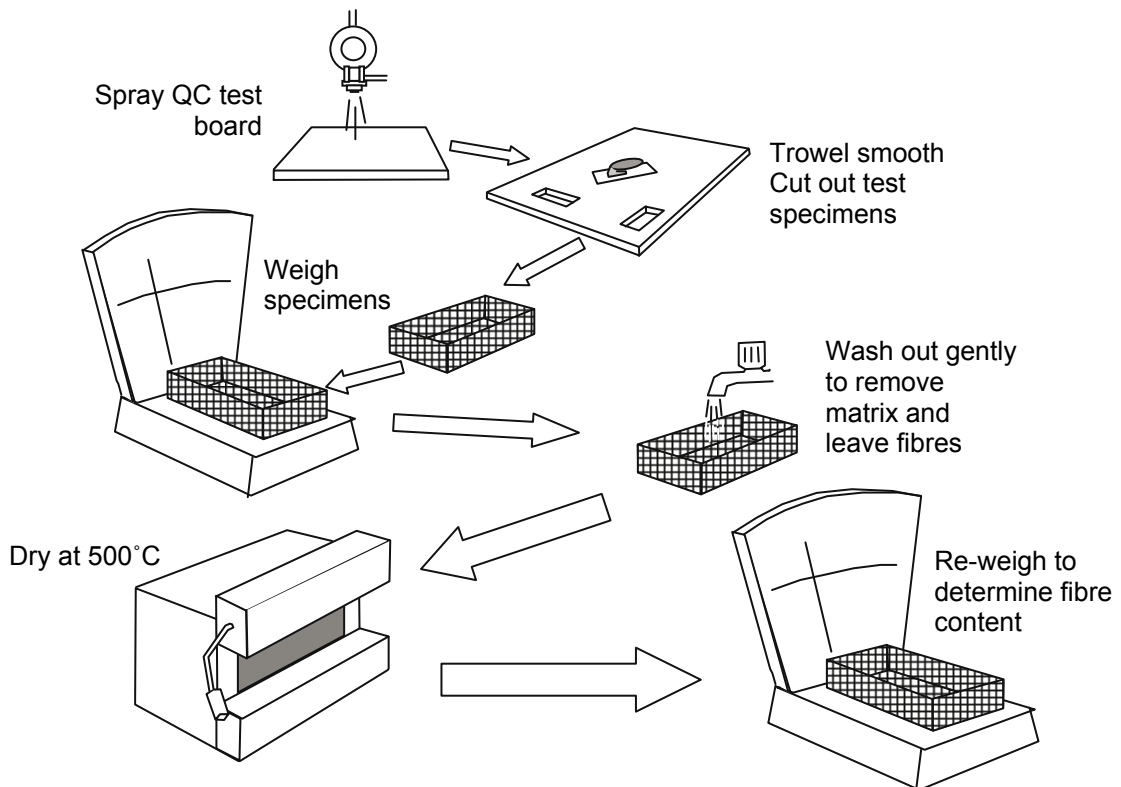

Procedure for determination of fibre content

Product Control

Tests on cured GRC specimens taken either from product or a test board representative of the product:

BS EN 1170-4 Measuring bending strength - "Simplified bending test" method.

BS EN 1170-5 Measuring bending strength - "Complete bending test" method.

BS EN 1170-6 Determination of absorption of water by immersion and determination of the dry density.

BS EN 1170-7 Measurement of extremes of dimensional variations due to moisture movement

BS EN 1170-8 Cyclic weathering type test

Component Inspection and Testing

Final product inspection for surface flaws, colour, finish and overall product dimensions should always be carried out. In certain circumstances it may be necessary to test the finished product mechanically.

12. CURING OF GRC PRODUCTS

Two types of curing system are employed with GRC: moist cure and air cure. Whichever system is used the curing process should be well established and controlled so that adequate strength is achieved, and to minimise any surface blemishes and non-uniformity of colour.

Moist Cure

Thin section GRC products with low water / cement ratios can rapidly dry out. If this occurs before hydration is complete shrinkage cracking may occur, and also the cement never achieves its full strength, therefore the properties of the GRC are adversely affected.

To ensure complete hydration, it is essential that products are covered immediately after manufacture to prevent drying, and to allow sufficient strength to be developed for demoulding. After demoulding the products should be kept in a damp condition so that curing can continue. Several methods of achieving this are currently in use, including storage in a humidity chamber or fog room, sealing in polythene bags, or total immersion in water.

As a guide to practical curing regimes, GRC products will achieve a substantial proportion of their ultimate strength when the main cure is carried out for 7 days, in a humidity of greater than 95% RH and with a minimum temperature of 20°C. A suitable post-curing regime will allow the remainder of the strength to be achieved. (For more information consult 'Cem-FIL[®] GRC Technical Data' Manual).

Air Cure

The incorporation of acrylic based polymeric materials into the GRC formulations provides the capability for air curing. The polymer formulation used must be capable of forming a film around the mix particles, thus allowing the moisture in the GRC to be retained and hydration to continue. The polymer materials are normally added at rates of between 3% - 5% of polymer solids to cement weight.

After initial cure under polythene and demoulding, the GRC product can be allowed to cure in ambient air conditions, but care must be taken to ensure that the air temperature is above the minimum film formation temperature of the polymer. The addition of polymer materials to GRC **may** affect the fire performance properties.

(For further information on the use of polymers please contact your representative at OCV™ Reinforcements).

13. CLEANING

A common cause of a stoppage in production is blockage of the pump or spray nozzle due to inadequate cleaning.

Clean equipment is essential for the consistent production of good quality GRC. Cleaning should be carried out at the end of the working day or when there is a long stoppage in production.

1. Hopper and Sieve

Pour clean water into pump hopper and hose down the hopper sides while running the pump. The sieve to the hopper should be cleaned at the same time.

(Note: The sieve should be rinsed every time a mix is put through).

2. Pump

In a pump with a rotor and stator the use of a quick release fitting on the pump foot enables the pump to be easily removed for thorough cleaning. Cleaning of the pump itself is important because cement can build up in the pump and begin to flake off after a day or so, thus blocking the spray nozzle. The rotor and stator assembly needs dismantling at the end of the production period for thorough cleaning.

A peristaltic pump can be cleaned using spherical sponges (placing them in the hopper and then assisting them into the pump with a blast of water).

3. Hoses

These can be cleaned by passing a spherical sponge of diameter slightly larger than the hose diameter through the hose while running the pump. For a pump with a rotor and stator the sponge should be introduced at the end of the hose and not through the hopper.

4. Spray Outlets

These should be cleaned with a 'bottle' brush or metallic brush and thoroughly dried to reduce corrosion.

5. Rollers and Trowels

These should be thoroughly cleaned with a stiff brush to remove cement build-up between the vanes and on the surfaces.

14. CHECK LIST

Remember

1. Increasing the spray rate does not necessarily increase the overall production rate and may reduce quality on anything other than simple flat moulds.
2. Good teamwork means good productivity.
3. Reducing the fibre content is FALSE economy. Always ensure the achievement of designed properties.
4. Do not allow one layer of sprayed material to set before spraying the next layer as this will produce a weak product.
5. Good compaction is necessary to achieve good mechanical properties.

Do

1. Keep a stock of chopper blades and backing rollers
2. Keep at least one spare concentric spray gun
3. Keep the spray equipment clean
4. Allow time at the end of a shift for cleaning down
5. Train production personnel
6. Use Quality & Process Control procedures to obtain accurate knowledge of the product's mechanical properties.

NORTH AMERICA

James PATTERSON
TEL: +1 623-566-0260
FAX: +1 208-730-4581
Cem-fil@owenscorning.com

EUROPE

Holger ZORN
TEL: +32.2.674.8318
FAX: +32.2.662.0815
Cem-fil@owenscorning.com

ASIA PACIFIC

Peter RIDD
TEL: +44 1275.390.968
FAX: +44 117.370.1075
Cem-fil@owenscorning.com

MIDDLE EAST AND AFRICA

Brian MARTEN
FAX: +44 (0) 8701123811
Cem-fil@owenscorning.com

**OCV™ Reinforcements****OWENS CORNING**

COMPOSITE MATERIALS, LLC
ONE OWENS CORNING PARKWAY
TOLEDO, OHIO 43659
1.800.GET.PINK™
www.owenscorning.com
www.ocvreinforcements.com

**EUROPEAN OWENS CORNING
FIBERGLAS, SPRL.**

166, CHAUSSEE DE LA HULPE
B-1170 BRUSSELS
BELGIUM
+32.2.674.82.11

OWENS CORNING

OCV Asia Pacific
SHANGHAI REGIONAL HEADQUARTERS
2F OLIVE LVO MANSION 620 HUA SHAN ROAD
SHANGHAI CHINA 200040
+86.21.62489922

This information and data contained herein is offered solely as a guide in the selection of a reinforcement. The information contained in this publication is based on actual laboratory data and field test experience. We believe this information to be reliable, but do not guarantee its applicability to the user's process or assume any responsibility or liability arising out of its use or performance. The user agrees to be responsible for thoroughly testing any application to determine its suitability before committing to production. It is important for the user to determine the properties of its own commercial compounds when using this or any other reinforcement. Because of numerous factors affecting results, we make no warranty of any kind, express or implied, including those of merchantability and fitness for a particular purpose. Statements in this publication shall not be construed as representations or warranties or as inducements to infringe any patent or violate any law safety code or insurance regulation.

Pub. No. 10010752 Owens Corning reserves the right to modify this document without prior notice. ©2009 Owens Corning

Cemfil_Sprayguide_ww_12-2008_Rev1